

DIGITAL CONTROLLED STEREO AUDIO PROCESSOR

- SINGLE SUPPLY OPERATION
- FOUR STEREO INPUT SOURCE SELECTION
- MONO INPUT
- TREBLE, BASS, VOLUME, AND BALANCE CONTROL
- FOUR INDEPENDENT SPEAKER CONTROL (FRONT/REAR)
- SINGLE SUPPLY OPERATION
- ALL FUNCTIONS PROGRAMMABLE VIA SERIAL BUS
- VERY LOW NOISE AND VERY LOW DISTORTION
- POP FREE SWITCHING

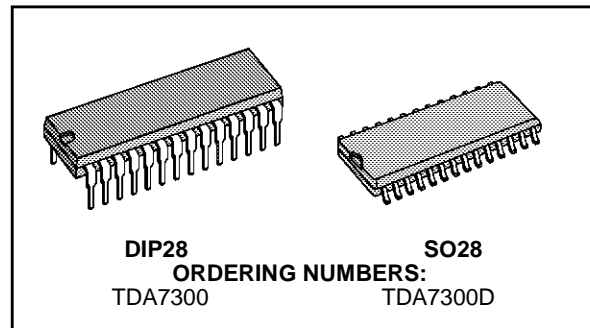

processor for high quality audio applications in car radio and Hi-Fi systems.

Control is accomplished by serial bus microprocessor interface. The AC signal setting is obtained by resistor networks and analog switches combined with operational amplifiers. The results are: low noise, low distortion and high dynamic range.

DESCRIPTION

The TDA7300 is a volume, tone (bass and treble), balance (left/right) and fader (front/rear) processor.

BLOCK DIAGRAM

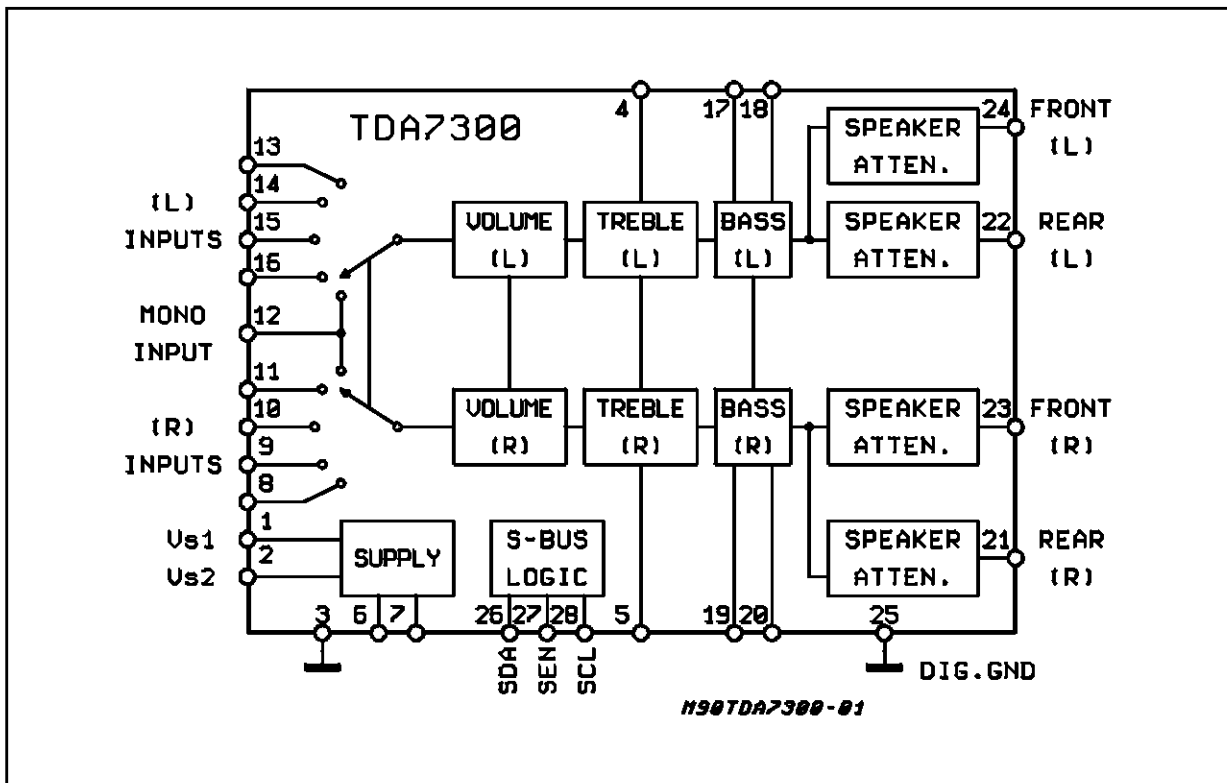

TDA7300

PIN CONNECTION (Top view)

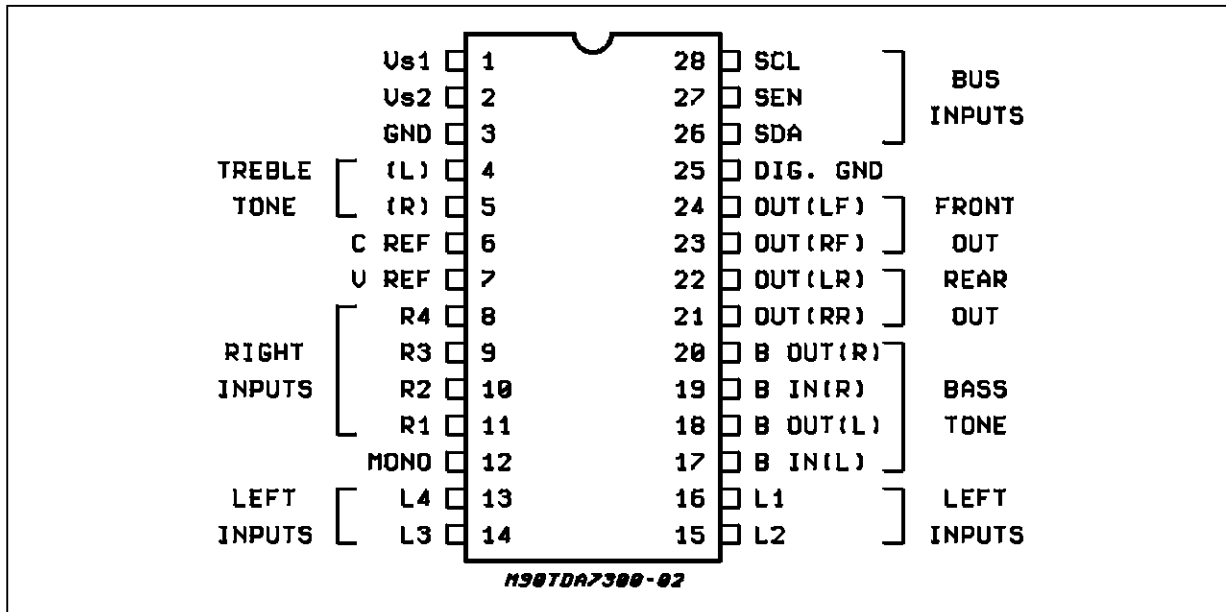

ABSOLUTE MAXIMUM RATINGS

| Symbol | Parameter | Value | Unit |
|-----------|-------------------------------------|------------|------|
| V_S | Supply Voltage (V_{S1}) | 18 | V |
| T_{amb} | Operating Ambient Temperature Range | -40 to +85 | °C |
| T_{stg} | Storage Temperature | -40 to 150 | °C |

THERMAL DATA

| Symbol | Description | SO28 | DIP28 | Unit |
|------------------|----------------------------------|------|-------|------|
| $R_{th\ j-pins}$ | Thermal Resistance Junction-pins | 85 | 65 | °C/W |

ELECTRICAL CHARACTERISTICS ($T_{amb} = 25^\circ\text{C}$, $V_{S1} = 12\text{V}$ or $V_{S2} = 8.5\text{V}$, $R_L = 10\text{k}\Omega$ and $R_g = 600\Omega$, $f = 1\text{KHz}$ unless otherwise specified)

| Symbol | Parameter | Test Condition | Min. | Typ. | Max. | Unit |
|--------|-----------|----------------|------|------|------|------|
|--------|-----------|----------------|------|------|------|------|

SUPPLY (1)

| | | | | | | |
|-----------|------------------------------|--------------------------------------|-----|-----|----|----|
| V_{S1} | Supply Voltage V_{S1} | | 10 | 12 | 16 | V |
| V_{S2} | Supply Voltage V_{S2} | | 6 | 8.5 | 10 | V |
| I_{S2} | Supply Current | | 15 | 30 | 40 | mA |
| V_{ref} | Reference Voltage (pin 7) | | 3.5 | 4.3 | 5 | V |
| SVR | Ripple Rejection at V_{S1} | $f = 300\text{Hz}$ to 10KHz | 80 | 97 | | dB |
| SVR | Ripple Rejection at V_{S2} | $f = 300\text{Hz}$ to 10KHz | 50 | 58 | | dB |

INPUT SELECTORS

| | | | | | | |
|---------------|-------------------|-------------------------------|-----|-----|---|------------------|
| R_i | Input Resistance | | 30 | 45 | | $\text{K}\Omega$ |
| $V_{IN\ max}$ | Max. Input Signal | $GV = 0\text{dB}$ $d = 0.3\%$ | 1.5 | 2.2 | | V_{rms} |
| IN_s | Input Separation | $f = 1\text{KHz}$ (2) | 90 | 100 | | dB |
| | | $f = 10\text{KHz}$ (2) | 70 | 80 | | dB |
| $V_i\ (DC)$ | Input DC Voltage | | 3.5 | 4.3 | 5 | V |

ELECTRICAL CHARACTERISTICS (continued)

| Symbol | Parameter | Test Condition | Min. | Typ. | Max. | Unit |
|--------|-----------|----------------|------|------|------|------|
|--------|-----------|----------------|------|------|------|------|

VOLUME CONTROLS

| | | | | | | |
|-----------|----------------------|---------------------|----|----|----|----|
| | Control Range | | | 78 | | dB |
| G_{max} | Max Gain | | 8 | 10 | 12 | dB |
| | Max Attenuation | | 64 | 68 | | dB |
| | Step Resolution | $G_V = -50$ to 10dB | | 2 | 3 | dB |
| | Attenuator Set Error | | | | 2 | dB |
| | Tracking Error | | | | 2 | dB |

SPEAKER ATTENUATORS

| | | | | | | |
|--|----------------------|--|----|----|----|----|
| | Control Range | | 35 | 38 | 41 | dB |
| | Step Resolution | | | 2 | 3 | dB |
| | Attenuator Set Error | | | | 2 | dB |
| | Tracking Error | | | | 2 | dB |

BASS AND TREBLE CONTROL (3)

| | | | | | | |
|--|-----------------|--|--|----------|-----|----|
| | Control Range | | | ± 15 | | dB |
| | Step Resolution | | | 2.5 | 3.5 | dB |

AUDIO OUTPUT

| | | | | | | |
|-----------|-------------------------|-------------|-----|-----|-----|------------|
| V_O | Max. Output Voltage | $d = 0.3\%$ | 1.5 | 2.2 | | Vrms |
| R_L | Output Load Resistance | | 2 | | | K Ω |
| C_L | Output Load Capacitance | | | | 1 | nF |
| R_O | Output Resistance | | | 70 | 150 | Ω |
| $V_O(DC)$ | DC Voltage Level | | 3 | 3.8 | 4.5 | V |

GENERAL

| | | | | | | |
|----------|-------------------------------|---|-------------|------|-----|-----------|
| e_{NO} | Output Noise | BW = 22Hz to 22KHz, $G_V = 0$ dB | | 6 | 15 | μ V |
| | | Curve A $G_V = 0$ dB | | 4 | | |
| S/N | Signal to Noise Ratio | All gain = 0dB $V_O = 1$ Vrms BW = 22Hz to 22KHz | | 105 | | dB |
| d | Distortion | $f = 1$ KHz; $V_O = 1$ V; $G_V = 0$ | | 0.01 | 0.1 | % |
| | Frequency Response (-1dB) | $G_V = 0$ | High Low | 20 | 20 | KHz Hz |
| S_C | Channel Separation left/right | $f = 1$ KHz | | 90 | 100 | dB |
| | | $f = 10$ KHz | | 70 | 80 | |

BUS INPUTS

| | | | | | | |
|----------|--------------------------------|--------------|-----|--|-----|---------|
| V_{IL} | Input LOW Voltage | | | | 0.8 | V |
| V_{IH} | Input HIGH Voltage | | 2.4 | | | V |
| V_O | Output Voltage SDA Acknowledge | $I = 1.6$ mA | | | 0.4 | V |
| | Digital Input Current | | -5 | | +5 | μ A |

Notes:

- (1) The circuit can be supplied either at V_{S1} or without the use of the internal voltage regulator at V_{S2} . The circuit also operates at a supply voltage V_{S1} lower than 10V. In this case the ripple rejection of V_{S2} is valid, because the voltage regulator saturates to a saturation voltage of about 0.8V.
- (2) The selected input is grounded thru the 2.2 μ F capacitor.
- (3) Bass and Treble response see attached diagram. The center frequency and quality of the resonance behaviour can be chosen by the external circuitry. A standard first order bass response can be realized by a standard feedback network.

TDA7300

Figure 1: Application Circuit

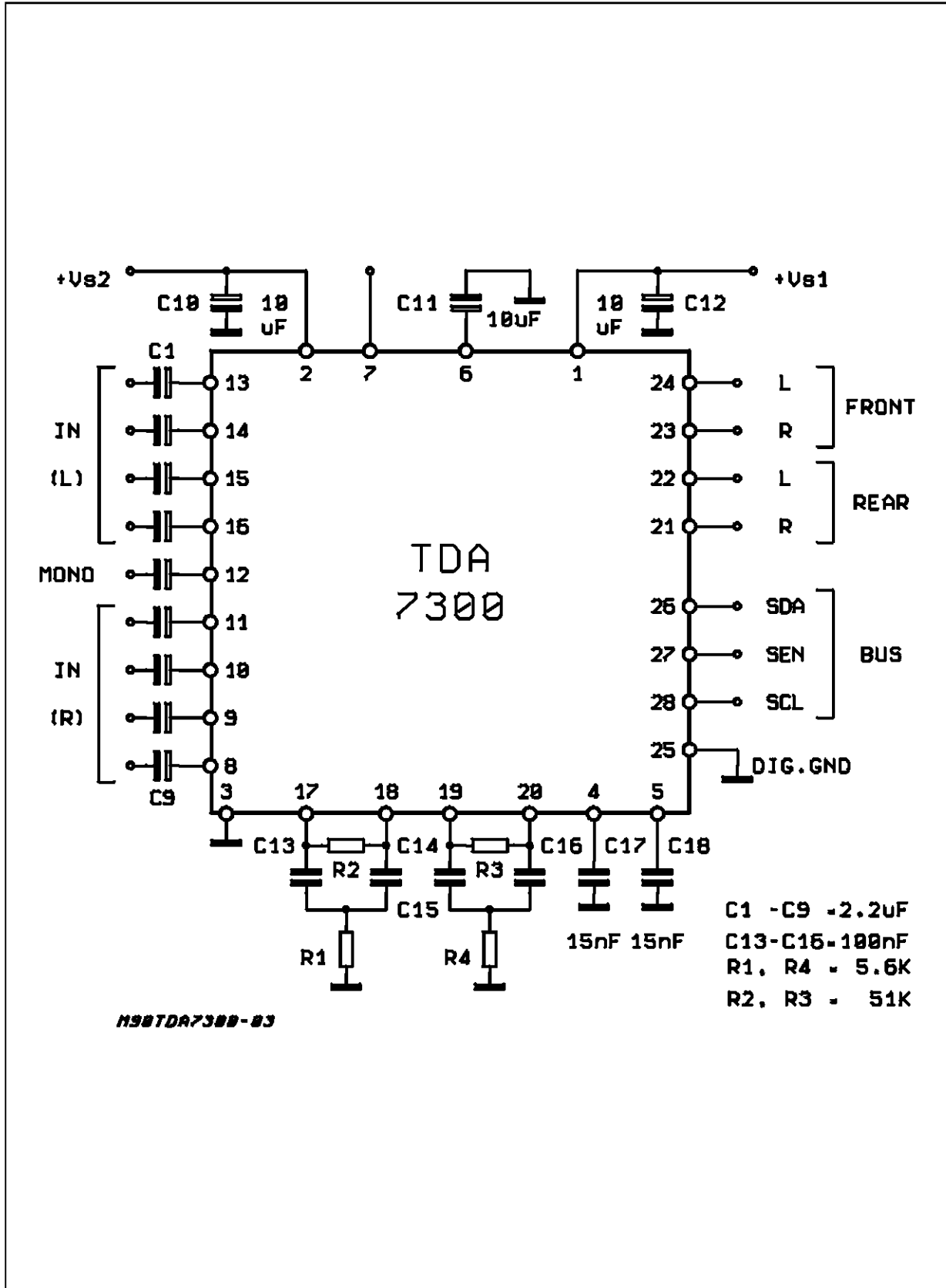

Figure 2: P.C. Board and Components Layout of the Fig.1 (1:1 scale)

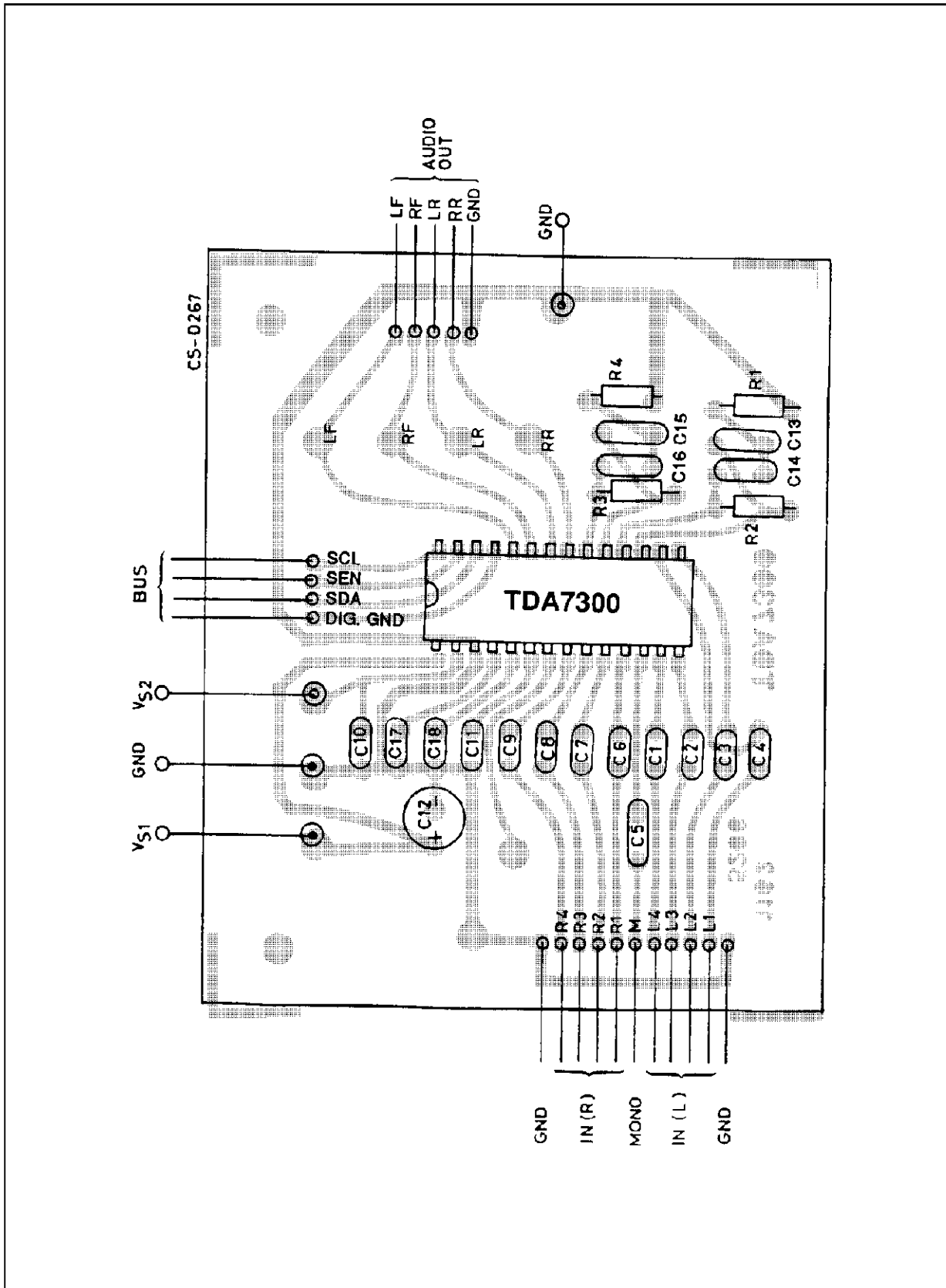

Figure 3: Total Output Noise vs. Volume Setting

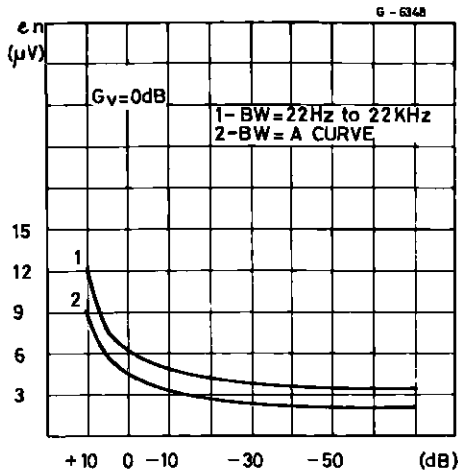

Figure 5: Distortion + Noise vs. Frequency

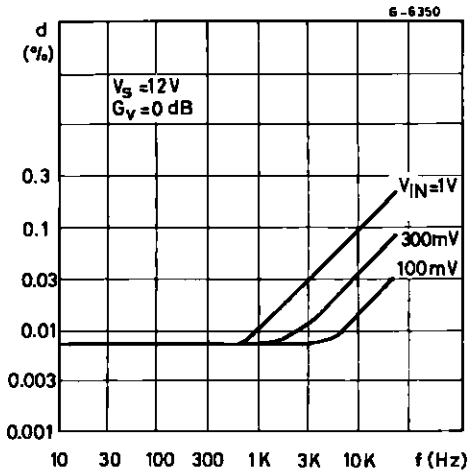

Figure 7: Distortion vs. Load Resistance

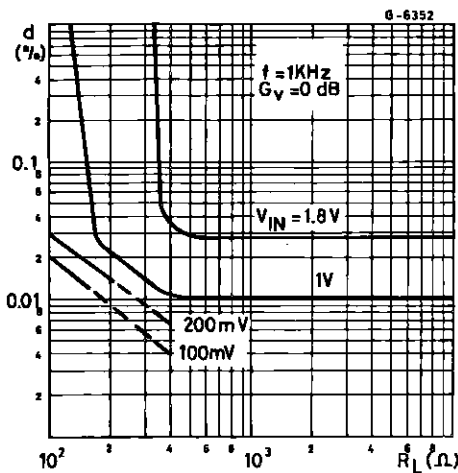

Figure 4: Signal to Noise Ratio vs. Volume Setting

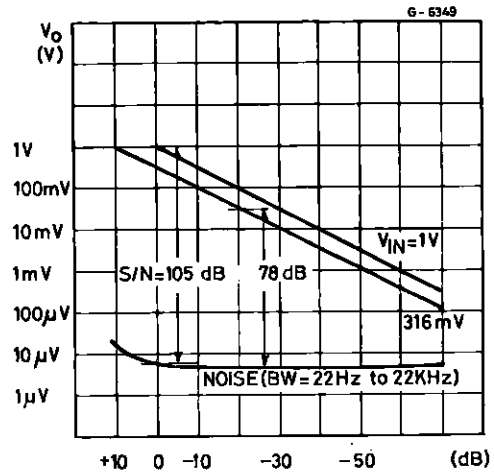

Figure 6: Distortion vs. Output Voltage

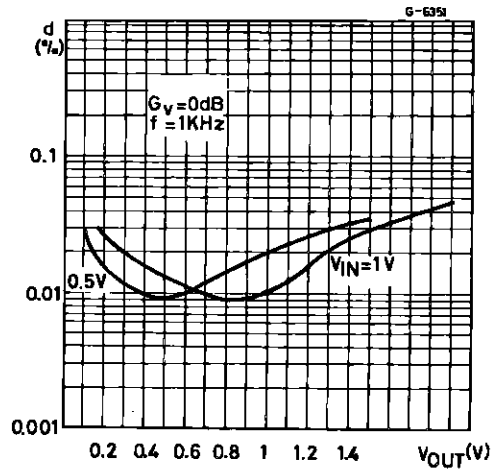

Figure 8: Channel Separation (L1 - R1) vs. Frequency

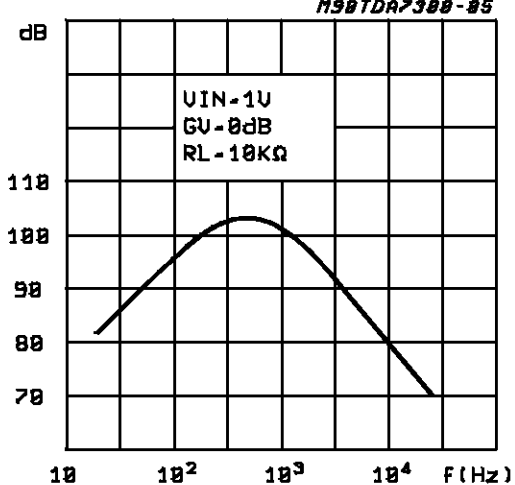

Figure 9: Input Separation (L1 - L2) vs. (V_{S1}) Frequency

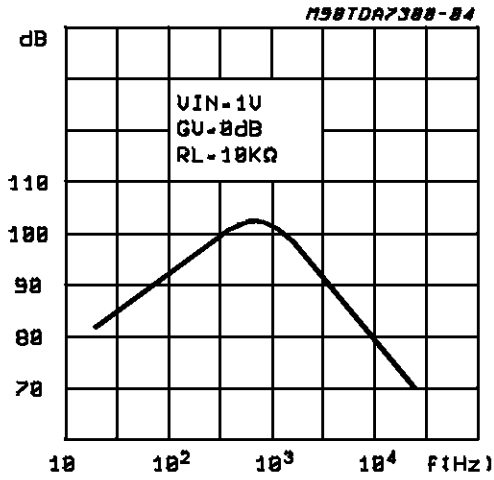

Figure 10: Supply Voltage Rejection (V_{S1}) vs. Frequency

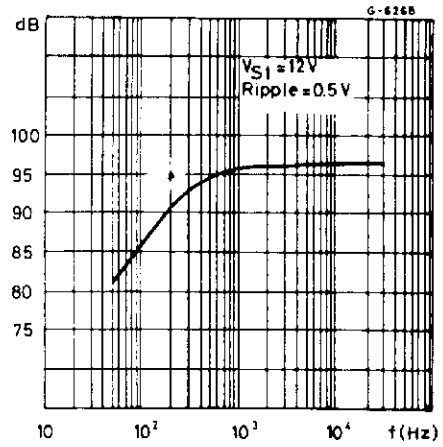

Figure 11: Supply Voltage Rejection (V_{S2}) vs. Frequency

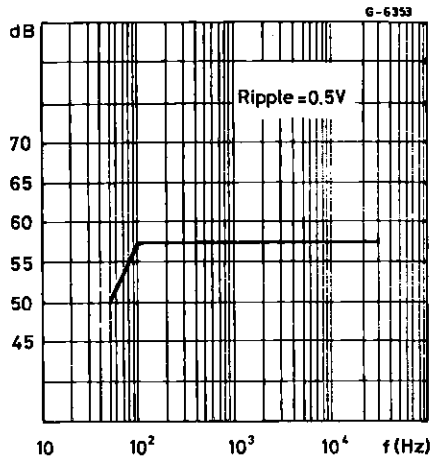

Figure 12: Supply Voltage Rejection vs. V_{S1}

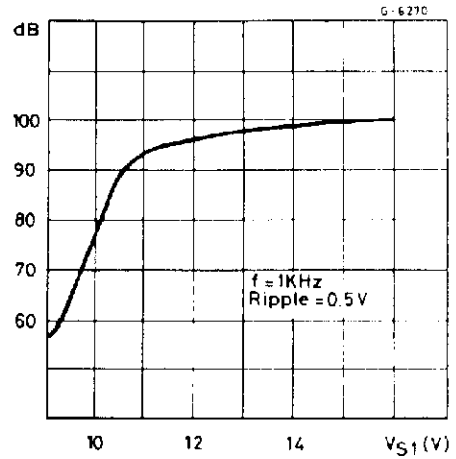

Figure 13: Supply Voltage Rejection vs. V_{S2}

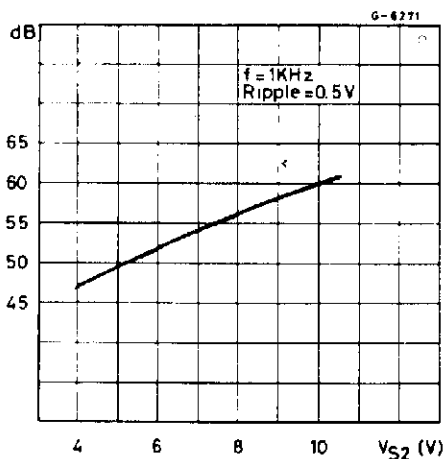
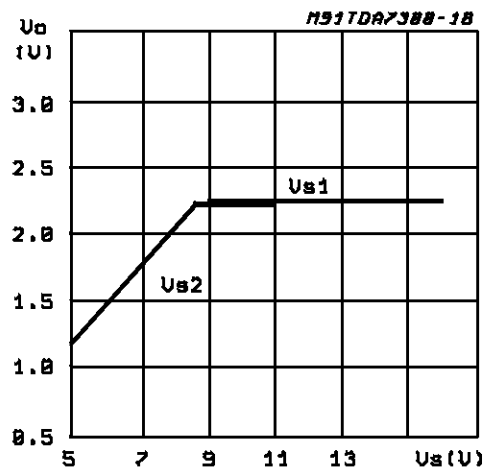

Figure 14: Clipping Level (V_{rms}) vs. Supply Voltage



APPLICATION INFORMATION

Volume Control Concept

Traditional electronic volume control circuits use a multiplier technique with all the disadvantages of high noise and distortion.

The used concept, as shown in Fig. 15 with digital switched resistor dividers, provides extremely low noise and distortion. The multiplexing of the resistive dividers is realized with a multiple-input operational amplifier.

Bass and Treble Control

The principle operation of the bass control is shown in Fig. 16. The external filter together with the internal buffer allows a flexible filter design according to the different requirements in car radios. The function of the treble is similar to the bass. A typical curve is shown in Fig.19.

Outputs

A special class-A output amplifier with a modulated sink current provides low distortion and ground compatibility with low current consumption.

Figure 15: Volume Control

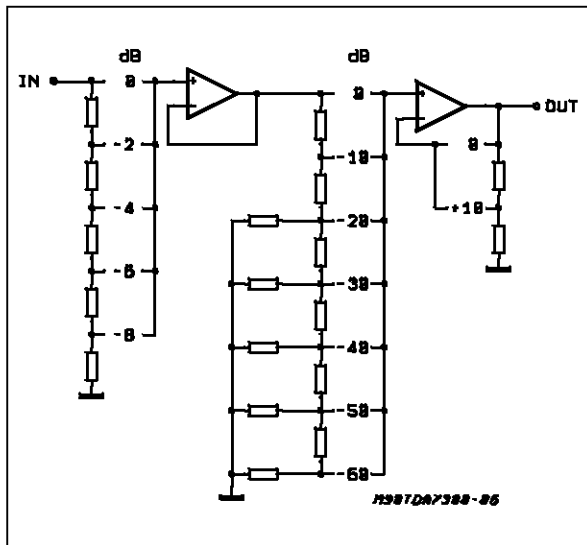

Figure 16: Bass Control

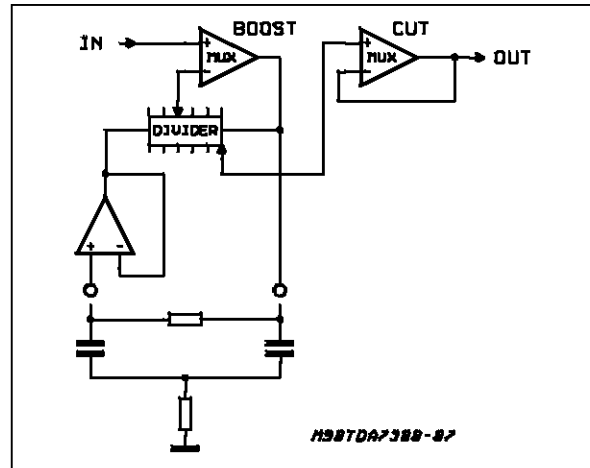

Figure 17: Quiescent Current vs. Supply Voltage

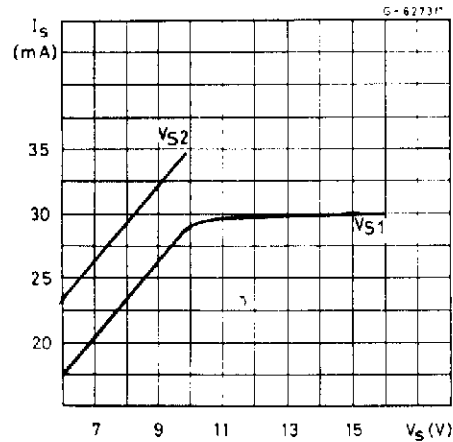
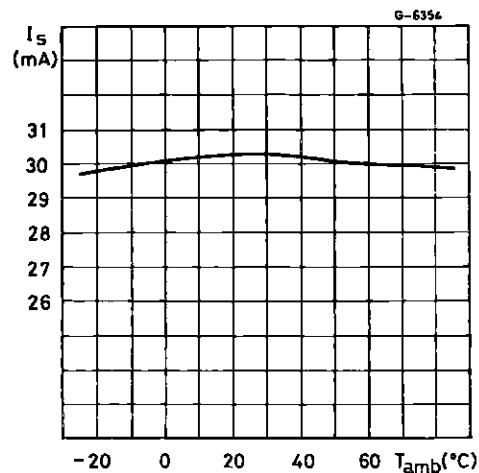

Figure 18: Quiescent Current vs. Temperature



APPLICATION INFORMATION (continued)

Figure 19: Typical Tone Response

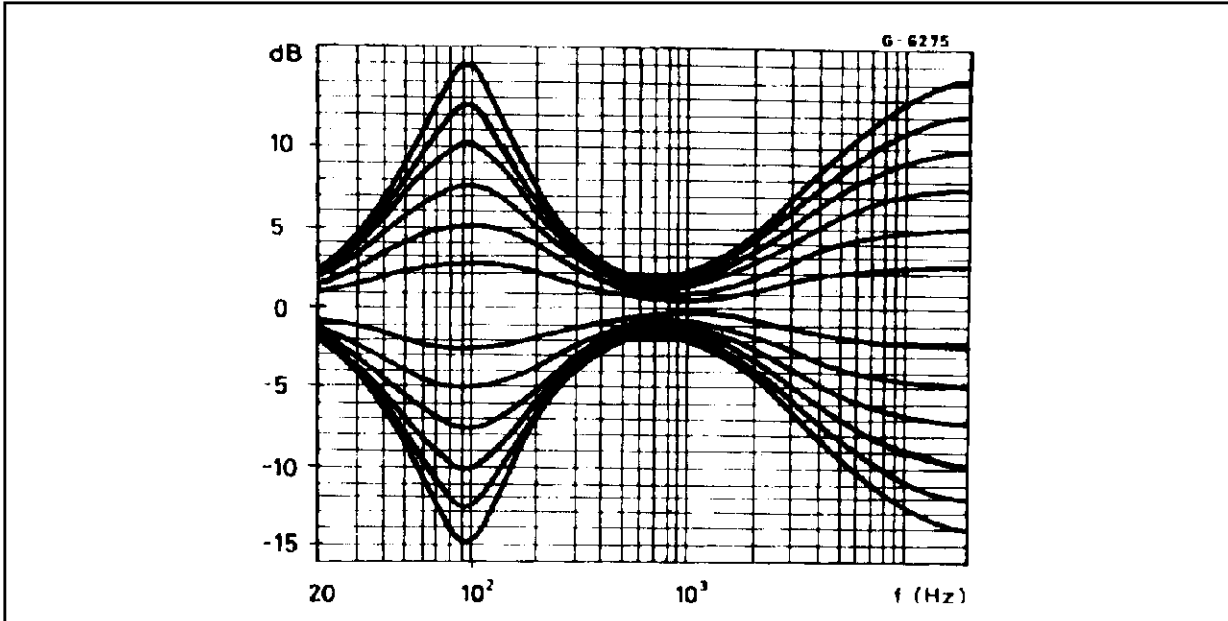
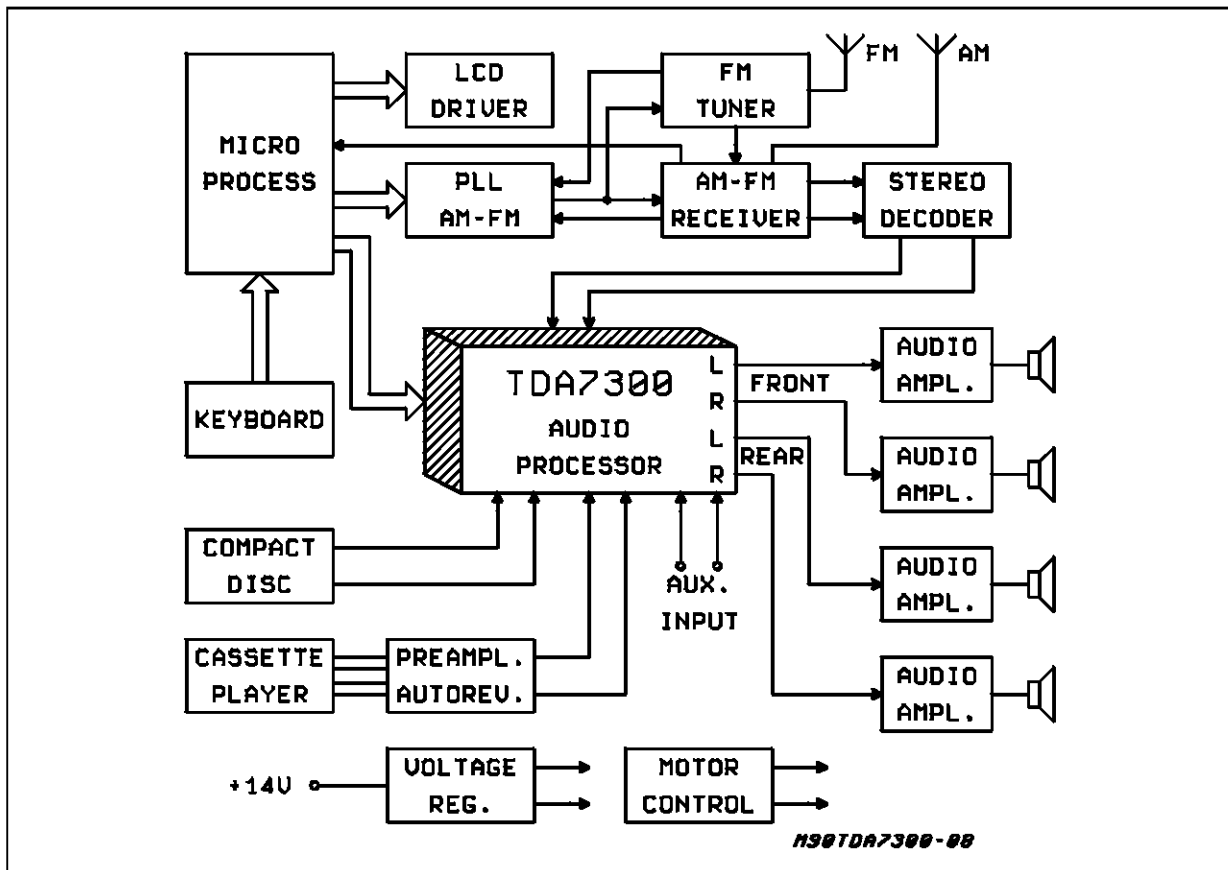

Figure 20: Complete Car-Radio System using Digital Controlled Audio Processor



APPLICATION INFORMATION (continued)

SERIAL BUS INTERFACE

S-BUS Interface and I²C BUS Compatibility

Data transmission from microprocessor to the TDA7300 and viceversa takes place thru the 3-wire S-BUS interface, consisting of the three lines SDA, SCL, SEN. If SDA and SEN inputs are short-circuited together, then the TDA7300 appears as a standard I²C BUS slave.

According to I²C BUS specification the S-BUS lines are connected to a positive supply voltage via pull-up resistors.

LOW transition of the SDA line while SCL is HIGH. The stop condition is a LOW to HIGH transition of the SDA line while SCL is HIGH.

S-bus:

the start/stop conditions (points 1 and 6) are detected exclusively by a transition of the SEN line (1 → 0 / 0 → 1) while the SCL line is at the HIGH level.

The SDA line is only allowed to change during the time the SCL line is low (points 2, 3, 4, 5). After the start information (point 1) the SEN line returns to the HIGH level and remains unchanged for all the time the transmission is performed.

Data Validity

As shown in fig. 21, the data on the SDA line must be stable during the high period of the clock. The HIGH and LOW state of the data line can only change when the clock signal on the SCL line is LOW.

Figure 21: Data Validity on the I²C BUS

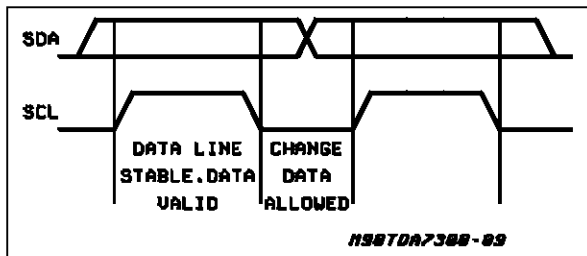

Byte Format

Every byte transferred on the SDA line must contain 8 bits. Each byte must be followed by an acknowledge bit. The MSB is transferred first.

Acknowledge

The master (μP) puts a resistive HIGH level on the SDA line during the acknowledge clock pulse (see fig. 23). The peripheral (audioprocessor) that acknowledges has to pull-down (LOW) the SDA line during the acknowledge clock pulse, so that the SDA line is stable LOW during this clock pulse.

The audioprocessor which has been addressed has to generate an acknowledge after the reception of each byte, otherwise the SDA line remains at the HIGH level during the ninth clock pulse time. In this case the master transmitter can generate the STOP information in order to abort the transfer.

Start and Stop Conditions

I²C BUS:

as shown in fig.22 a start condition is a HIGH to

Figure 22: Timing Diagram of S-BUS and I²C BUS

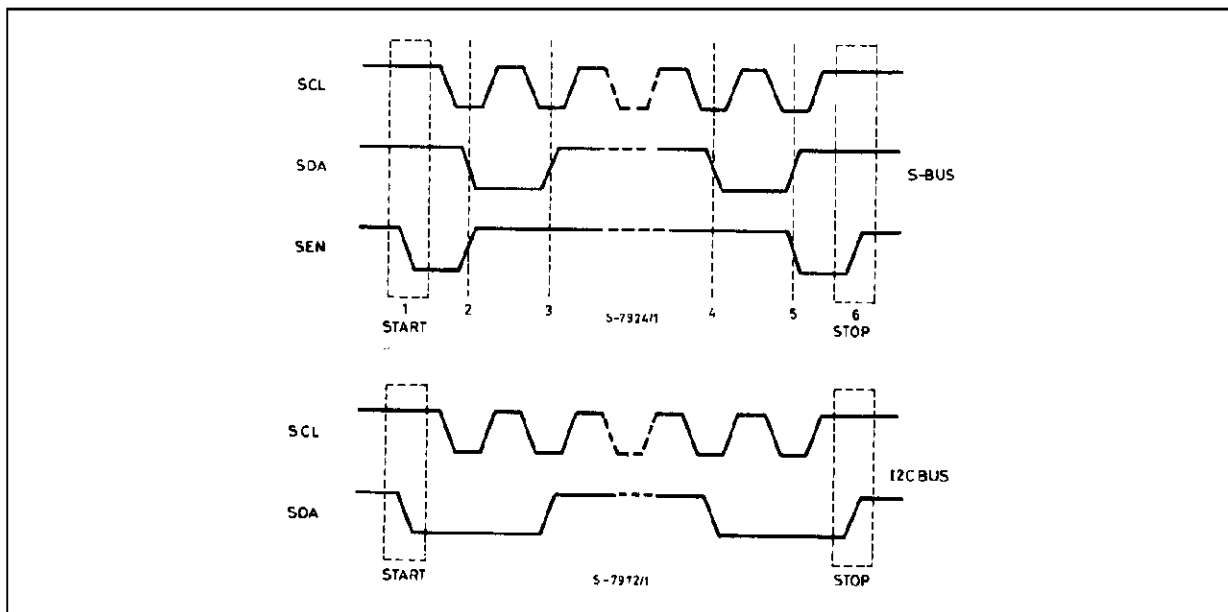

APPLICATION INFORMATION (continued)

Figure 23: Acknowledge on the I²C BUS

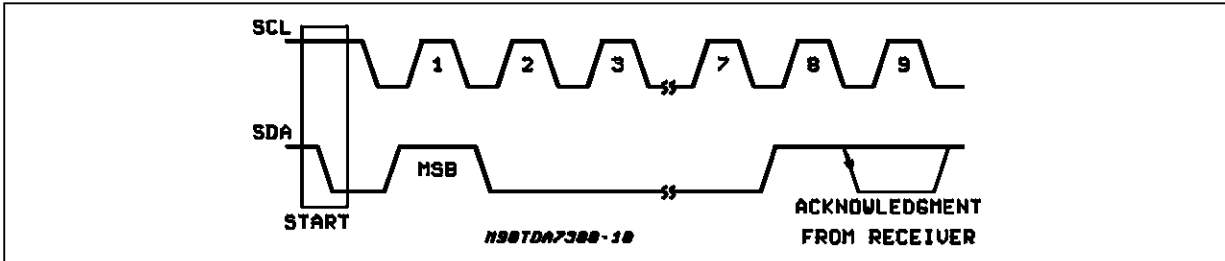

Transmission without Acknowledge

Avoiding to detect the acknowledge of the audio-processor, the μ P can use a simpler transmission: simply it waits one clock without checking the slave acknowledging, and sends the new data.

This approach of course is less protected from misworking and decreases the noise immunity.

Interface Protocol

The interface protocol comprises:

- A start condition (S)
- A chip address byte, containing the TDA7300 address (the 8th bit of the byte must be 0). The TDA7300 must always acknowledge at the end of each transmitted byte.
- A sequence of data (N-bytes + acknowledge)
- A stop condition (P)

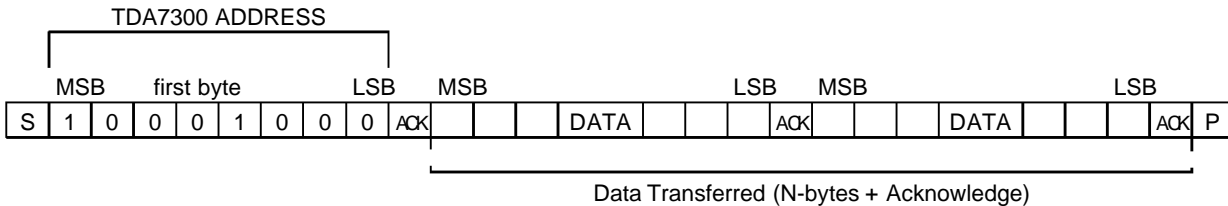

ACK = Acknowledge
S = Start
P = Stop

MAX CLOCK SPEED 100kbits/s

SOFTWARE SPECIFICATION

Chip address (TDA7300 address)

1 0 0 0 1 0 0 0
MSB LSB

DATA BYTES

| MSB | LSB | | | | | | | Function |
|-----|-----|----|----|----|----|----|----|----------------|
| 0 | 0 | B2 | B1 | B0 | A2 | A1 | A0 | Volume Control |
| 1 | 1 | 0 | B1 | B0 | A2 | A1 | A0 | Speaker ATT LR |
| 1 | 1 | 1 | B1 | B0 | A2 | A1 | A0 | Speaker ATT RR |
| 1 | 0 | 0 | B1 | B0 | A2 | A1 | A0 | Speaker ATT LF |
| 1 | 0 | 1 | B1 | B0 | A2 | A1 | A0 | Speaker ATT RF |
| 0 | 1 | 0 | X | X | S2 | S1 | S0 | Audio switch |
| 0 | 1 | 1 | 0 | C3 | C2 | C1 | C0 | Bass control |
| 0 | 1 | 1 | 1 | C3 | C2 | C1 | C0 | Treble control |

X = don't care
Ax = 2dB steps
Bx = 10dB steps
Cx = 2.5dB steps

Status after power-on reset

| | |
|--------------|--------|
| Volume | -68dB |
| Speaker | -38dB |
| Audio Switch | Mono |
| Bass | +2.5dB |
| Treble | +2.5dB |

TDA7300

SOFTWARE SPECIFICATION (continued) DATA BYTES (detailed description)

VOLUME

| MSB | | | LSB | | | |
|-----|---|----------|-------------------|------------------|--|--|
| 0 | 0 | B2 B1 B0 | A2 A1 A0 | Volume 2dB Steps | | |
| | | | 0 0 0 | 0 | | |
| | | | 0 0 1 | -2 | | |
| | | | 0 1 0 | -4 | | |
| | | | 0 1 1 | -6 | | |
| | | | 1 0 0 | -8 | | |
| | | | 1 0 1 | Not allowed | | |
| | | | 1 1 0 | Not allowed | | |
| | | | 1 1 1 | Not allowed | | |
| 0 | 0 | B2 B1 B0 | Volume 10dB steps | | | |
| | | 0 0 0 | +10 | | | |
| | | 0 0 1 | 0 | | | |
| | | 0 1 0 | -10 | | | |
| | | 0 1 1 | -20 | | | |
| | | 1 0 0 | -30 | | | |
| | | 1 0 1 | -40 | | | |
| | | 1 1 0 | -50 | | | |
| | | 1 1 1 | -60 | | | |

For example if you want setting the volume at -32dB the 8 bit string is: 0 0 1 0 0 0 0 1

SPEAKER ATTENUATORS

| MSB | | | LSB | | | |
|-----|---|---|-------|----------|-------------|--|
| 1 | 0 | 0 | B1 B0 | A2 A1 A0 | Speaker LF | |
| 1 | 0 | 1 | B1 B0 | A2 A1 A0 | Speaker RF | |
| 1 | 1 | 0 | B1 B0 | A2 A1 A0 | Speaker LR | |
| 1 | 1 | 1 | B1 B0 | A2 A1 A0 | Speaker RR | |
| | | | | 0 0 0 | 0 | |
| | | | | 0 0 1 | -2 | |
| | | | | 0 1 0 | -4 | |
| | | | | 0 1 1 | -6 | |
| | | | | 1 0 0 | -8 | |
| | | | | 1 0 1 | Not allowed | |
| | | | | 1 1 0 | Not allowed | |
| | | | | 1 1 1 | Not allowed | |
| | | | 0 0 | 0 | | |
| | | | 0 1 | -10 | | |
| | | | 1 0 | -20 | | |
| | | | 1 1 | -30 | | |

For example attenuation of 24dB on speaker RF is given by: 1 0 1 1 0 0 1 0

SOFTWARE SPECIFICATION (continued)

AUDIO SWITCH - Select the input Channel to Activate

| MSB | | | LSB | | | | | |
|-----|---|---|-----|---|----|----|----|--------------|
| 0 | 1 | 0 | X | X | S2 | S1 | S0 | Audio Switch |
| | | | X | X | 0 | 0 | 0 | Stereo 1 |
| | | | X | X | 0 | 0 | 1 | Stereo 2 |
| | | | X | X | 0 | 1 | 0 | Stereo 3 |
| | | | X | X | 0 | 1 | 1 | Stereo 4 |
| | | | X | X | 1 | 0 | 0 | Mono |
| | | | X | X | 1 | 0 | 1 | Not Allowed |
| | | | X | X | 1 | 1 | 0 | Not Allowed |
| | | | X | X | 1 | 1 | 1 | Not Allowed |

X = don't care

For example to set the stereo 2 channel the 8 bit string may be: 0 1 0 0 0 0 1

BASS AND TREBLE - Control Range of ± 15 dB (boost and cut) Steps of 2.5dB

| 0 | 1 | 1 | 0 | C3 | C2 | C1 | C0 | Bass |
|---|---|---|---|----|----|----|----|--------|
| 0 | 1 | 1 | 1 | C3 | C2 | C1 | C0 | Treble |
| | | | | 0 | 0 | 0 | 0 | - 15 |
| | | | | 0 | 0 | 0 | 1 | - 15 |
| | | | | 0 | 0 | 1 | 0 | - 12.5 |
| | | | | 0 | 0 | 1 | 1 | - 10 |
| | | | | 0 | 1 | 0 | 0 | - 7.5 |
| | | | | 0 | 1 | 0 | 1 | - 5 |
| | | | | 0 | 1 | 1 | 0 | - 2.5 |
| | | | | 0 | 1 | 1 | 1 | - 0 |
| | | | | 1 | 1 | 1 | 1 | 0 |
| | | | | 1 | 1 | 1 | 0 | 2.5 |
| | | | | 1 | 1 | 0 | 1 | 5 |
| | | | | 1 | 1 | 0 | 0 | 7.5 |
| | | | | 1 | 0 | 1 | 1 | 10 |
| | | | | 1 | 0 | 1 | 0 | 12.5 |
| | | | | 1 | 0 | 0 | 1 | 15 |
| | | | | 1 | 0 | 0 | 0 | 15 |

C3 = Sign

For example Bass at -12.5dB is obtained by the following 8 bit string: 0 1 1 0 0 1 0

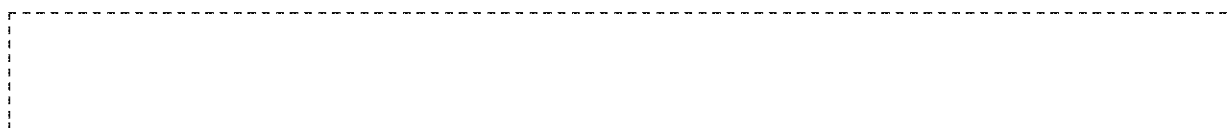

TDA7300

DIP28 PACKAGE MECHANICAL DATA

| DIM. | mm | | | inch | | |
|------|------|-------|-------|-------|-------|-------|
| | MIN. | TYP. | MAX. | MIN. | TYP. | MAX. |
| a1 | | 0.63 | | | 0.025 | |
| b | | 0.45 | | | 0.018 | |
| b1 | 0.23 | | 0.31 | 0.009 | | 0.012 |
| b2 | | 1.27 | | | 0.050 | |
| D | | | 37.34 | | | 1.470 |
| E | 15.2 | | 16.68 | 0.598 | | 0.657 |
| e | | 2.54 | | | 0.100 | |
| e3 | | 33.02 | | | 1.300 | |
| F | | | 14.1 | | | 0.555 |
| I | | 4.445 | | | 0.175 | |
| L | | 3.3 | | | 0.130 | |

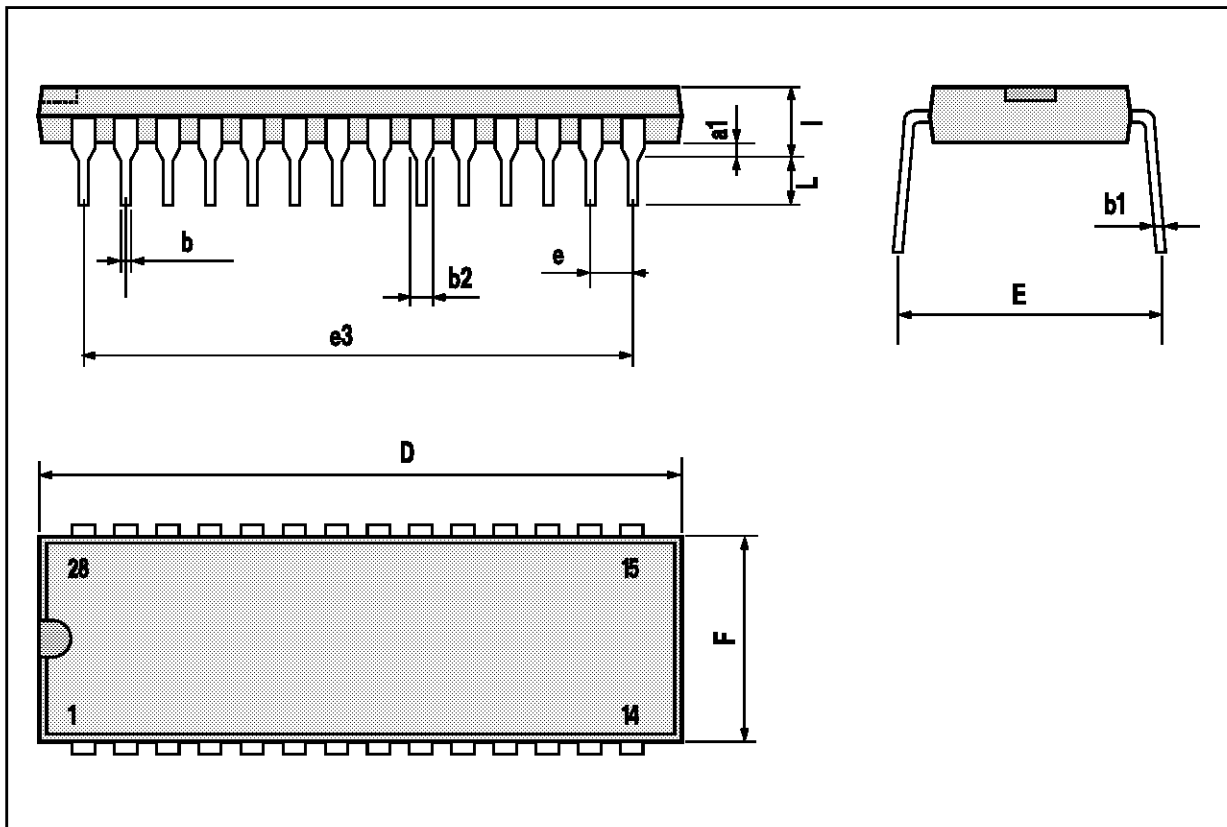

SO28 PACKAGE MECHANICAL DATA

| DIM. | mm | | | inch | | |
|------|------------|-------|-------|-------|-------|-------|
| | MIN. | TYP. | MAX. | MIN. | TYP. | MAX. |
| A | | | 2.65 | | | 0.104 |
| a1 | 0.1 | | 0.3 | 0.004 | | 0.012 |
| b | 0.35 | | 0.49 | 0.014 | | 0.019 |
| b1 | 0.23 | | 0.32 | 0.009 | | 0.013 |
| C | | 0.5 | | | 0.020 | |
| c1 | 45° (typ.) | | | | | |
| D | 17.7 | | 18.1 | 0.697 | | 0.713 |
| E | 10 | | 10.65 | 0.394 | | 0.419 |
| e | | 1.27 | | | 0.050 | |
| e3 | | 16.51 | | | 0.65 | |
| F | 7.4 | | 7.6 | 0.291 | | 0.299 |
| L | 0.4 | | 1.27 | 0.016 | | 0.050 |
| S | 8° (max.) | | | | | |

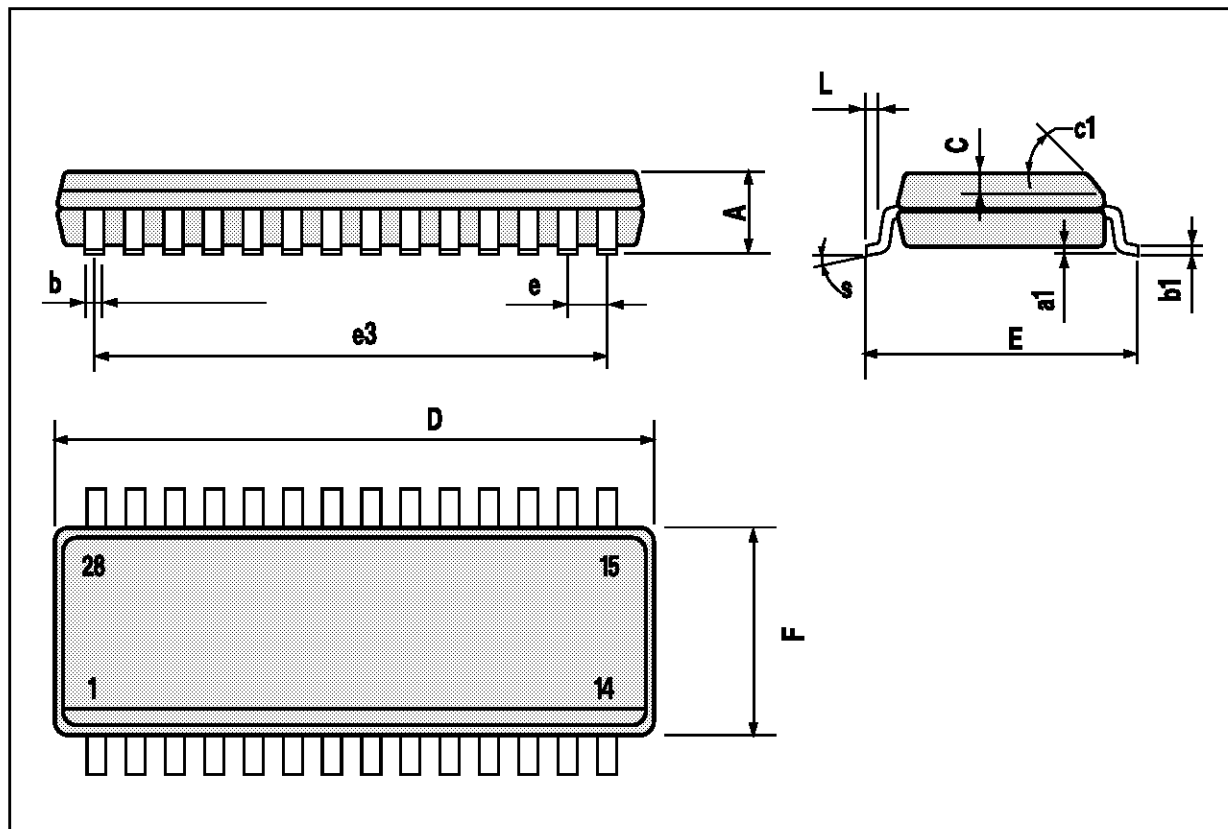

Information furnished is believed to be accurate and reliable. However, SGS-THOMSON Microelectronics assumes no responsibility for the consequences of use of such information nor for any infringement of patents or other rights of third parties which may result from its use. No license is granted by implication or otherwise under any patent or patent rights of SGS-THOMSON Microelectronics. Specifications mentioned in this publication are subject to change without notice. This publication supersedes and replaces all information previously supplied. SGS-THOMSON Microelectronics products are not authorized for use as critical components in life support devices or systems without express written approval of SGS-THOMSON Microelectronics.

© 1994 SGS-THOMSON Microelectronics - All Rights Reserved

Purchase of I²C Components of SGS-THOMSON Microelectronics, conveys a license under the Philips I²C Patent Rights to use these components in an I²C system, provided that the system conforms to the I²C Standard Specifications as defined by Philips.

SGS-THOMSON Microelectronics GROUP OF COMPANIES

Australia - Brazil - France - Germany - Hong Kong - Italy - Japan - Korea - Malaysia - Malta - Morocco - The Netherlands - Singapore - Spain - Sweden - Switzerland - Taiwan - Thailand - United Kingdom - U.S.A.